

Part Number: PL-FyUzz



**FEATURES:**

- Compliant with ANSI/EIA RS-310-D, IEC297-2, DIN41491.Part1, part7, DIN 4144 standards
- connected by four corner to ensure the stability
- cable entry from the top cover and bottom panel
- removable side doors for easy installation and maintenance
- 4 pcs of M12 adjustable feet and 4 pcs of 2" heavy duty castors included
- 1 pair of vertical cable management included for 800mm depth cabinet
- up to 800 kgs static loading capacity with adjustable feet

**Fan unit:**

- (2 fans with normal thermometer for 600mm depth cabinet)
- (4 fans with normal thermometer for 800mm depth cabinet)
- (4 fans with normal thermometer for 1000mm depth cabinet)

**Fixed shelf:**

- (2 shelf for 800mm depth cabinet from 22U to 32U)
- (3 shelf for 800mm depth cabinet from 37U to 42U)
- (2 shelf for 1000mm depth cabinet from 22U to 32U)
- (3 shelf for 1000mm depth cabinet from 37U to 42U)

**OPTIONAL DOORS:**

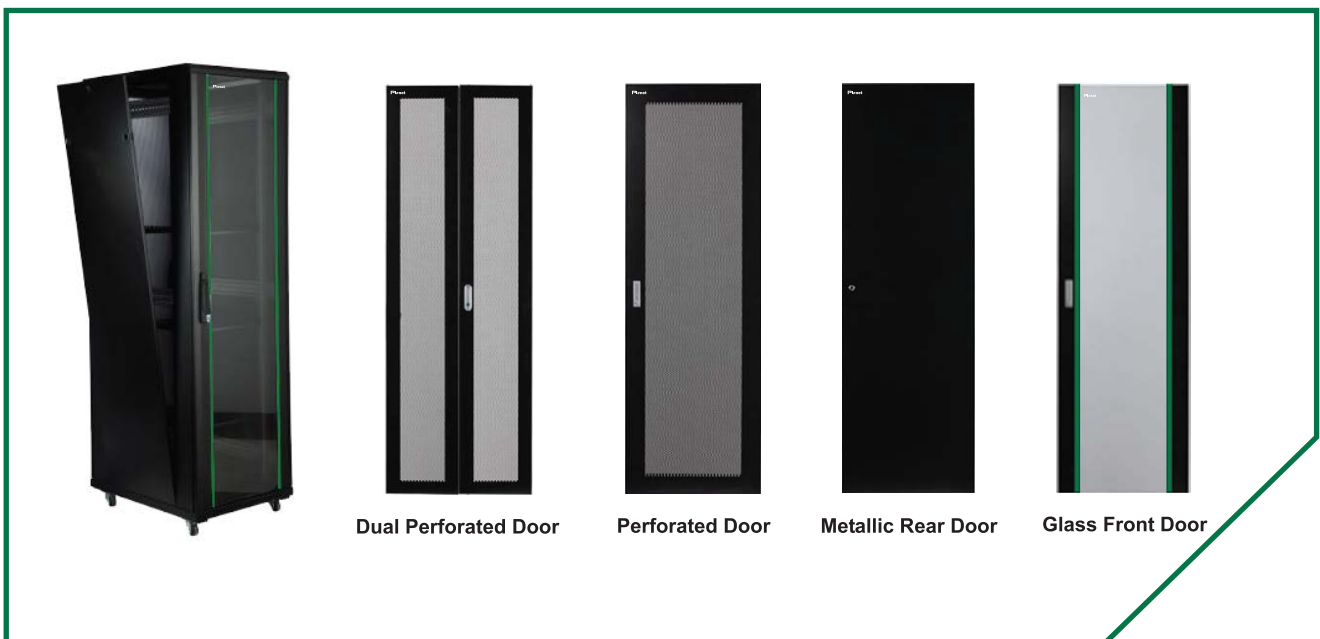

Dual Perforated Door

Perforated Door

Metallic Rear Door

Glass Front Door

Part Number: PL-FyUzz

Installation in Structure

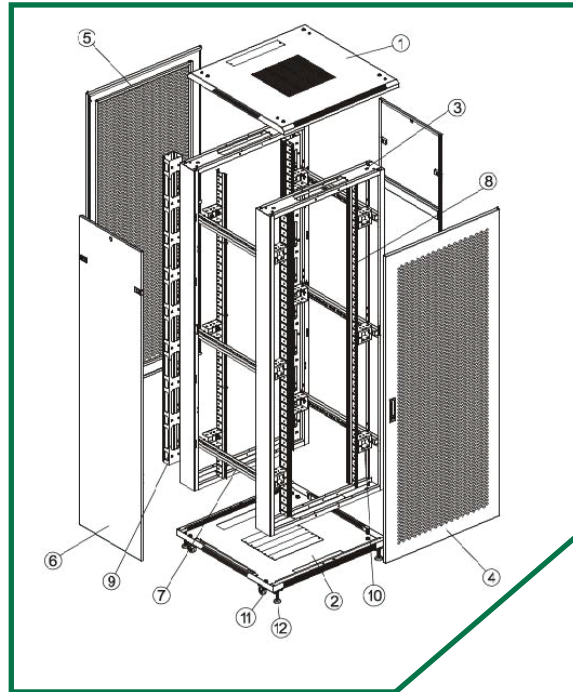

Main Parts:

S/N	Description	Quantity	Unit	Material	Surface finish	Remark
1	Top cover	1	Piece	SPCC cold rolled steel 1.2	Powder coated	—
2	Frame	2	Piece	SPCC Cold rolled steel 1.5	Powder coated	—
3	Front door	1	Piece	5MM Toughened glass	Powder coated	—
4	Side panel	2	Piece	SPCC Cold rolled steel 1.2	Powder coated	steel door
5	Rear door	1	Piece	SPCC Cold rolled steel 1.2	Powder coated	steel door
6	Bottom panel	1	Set	SPCC Cold rolled steel 1.2	Powder coated	—
7	Mounting angle	4/6	Piece	SPCC Cold rolled steel 1.5	Powder coated	4pcs for lower 27U
8	Mounting profile	4	Piece	SPCC Cold rolled steel 2.0	Powder coated	—
9	Spacer	8/12	Piece	SPCC Cold rolled steel 1.2	Powder coated	For 800mm width cabinet only
10	M6 screw	20/40	Set	—	—	40pcs for over 32U
11	Spring lock	2	Piece	—	—	With 4 keys
12	2.0" heavy duty castor	4	Piece	—	—	—
13	Adjustable feet	4	Piece	—	—	—
14	Allen wench	1	Piece	—	—	—

Remark: width 800mm and above 32U Cabinets with 12 spacer, lower 32U with 8 spacer

Part Number: PL-FyUzz

Dimensions:

Part NO.	Capacity(U)	Width(mm)	Depth(mm)	Height(mm)
PL-Fx22U66	22U	600	600	1166
PL-Fx22U68			800	
PL-Fx22U61			1000	
PL-Fx22U88		800	800	
PL-Fx22U81			1000	
PL-Fx27U66	27U	600	600	1388
PL-Fx27U68			800	
PL-Fx27U61			1000	
PL-Fx27U88		800	800	
PL-Fx27U81			1000	
PL-Fx32U66	32U	600	600	1610
PL-Fx32U68			800	
PL-Fx32U61			1000	
PL-Fx32U88		800	800	
PL-Fx32U81			1000	
PL-Fx37U66	37U	600	600	1833
PL-Fx37U68			800	
PL-Fx37U61			1000	
PL-Fx37U88		800	800	
PL-Fx37U81			1000	
PL-Fx42U66	42U	600	600	2055
PL-Fx42U68			800	
PL-Fx42U61			1000	
PL-Fx42U88		800	800	
PL-Fx42U81			1000	
PL-Fx47U81	47U		1000	2277

For doors material substitute "x" in PN

- G**= Glass Front Door + Metallic Rear Door
- K**= Glass Front Door + Perforated Rear Door
- H**= Perforated Front Door + Perforated Rear Door
- S**= Perforated Front Door + Dual Perforated Rear Door
- P**= Dual Perforated Front Door + Dual Perforated Rear Door